

AN EXPERIMENTAL STUDY OF THE THERMAL CONDUCTIVITY OF
CESIUM VAPOR BY THE PERIODIC HEATING METHOD

Yu. K. Vinogradov and A. V. Veryugin

UDC 536.23.546.311(045)

The periodic heating method is used to study the thermal conductivity of cesium vapor at temperatures of 1110-1170°K and pressures of 1-1.5 bar. Experimental results are presented.

Among experimental studies of the thermal conductivity of cesium vapor in the pressure and temperature range where dissociation has a significant effect on thermal conductivity, we have available at present [1-3]. In [1] two experimental points were obtained at close-lying temperatures (823 and 888°K) and pressures of 0.1 and 0.2 atm, respectively, with the 0.2 atm point proving to be 25% lower than that at 0.1 atm. That study was the first attempt to use the periodic heating method to study thermal conductivity of alkali metal vapors, and the results obtained are contradictory. In [2] measurements were performed by the coaxial cylinder method at temperatures up to 1087°K and pressures up to 1.4 bar, while the experimental error was estimated by the authors to be 6%. On the basis of their data the authors of [2] obtained thermal-conductivity values for the monatomic vapor λ_1 and separated the component of thermal conductivity connected with the dissociation reaction. A detailed study of cesium vapor thermal conductivity was performed in [3]. The experiments were performed by the hot-wire method, eliminating use of insulation materials in the measurement cell. Measurements were performed along isotherms from 800 to 1100°K at pressures of 0.03 to 2.5 atm. Also of interest is [4], in which measurements were performed by a variant of the hot-wire method and which studied the thermal conductivity of monatomic cesium vapor λ_1 in the interval 600-1600°K. The values of λ_1 obtained in [2] and [3] practically coincide, while those of [4] are 7-12% lower. The experiments of [4] were performed at relatively low pressures (1-5 mm Hg), so that the temperature change correction comprised 7-12%. In applying the correction the authors used their own equation for the pressure of saturated cesium vapor, apparently based on the experiments of [11, 12], which showed a large scattering in experimental points and low accuracy. The low pressures of saturated cesium vapor have recently been measured [5] with high-accuracy results (0.6%) in the pressure range of interest here. The vapor pressure values used in the temperature change correction of [4] prove to be 18% lower as compared to [5]. Using the correct saturated vapor pressure data of [5] leads to a reduction in the temperature change correction to the data of [4]. In this case the points obtained at various pressures will not fit a single curve when the temperature change model employed by the authors of [4, 6] is used. This is evidently because the experiments of [4] were performed at Knudsen numbers $Kn = l/r$ in the range 0.4-1.2. The experimental results of [2, 3] in the coordinates $(\lambda/\lambda_1) - x_2$ are shown in Fig. 1. It is obvious that the divergence of the 900°K isotherms is not more than 3%, while that of the 800 and 1000°K isotherms does not exceed 10%. The 1100°K isotherm of [3] lies significantly (up to 40%) higher than the results of [2]. It is thus of interest to measure the thermal conductivity of cesium vapor in the temperature range 1100-1200°K, where the divergence of previous experimental results was at a maximum.

The periodic heating method was chosen because of its several advantages over stationary methods in the high-temperature range, in particular, elimination of the need to measure a small temperature difference and a small correction for radiation. The method is based on measuring pulsations in the temperature of a low-inertia sensor (a 5- μ m diameter wire) heated by an ac current. The amplitude of the pulsations depends on the properties of the medium in which the sensor is located. With consideration of temperature change and heat transfer by radiation this dependence can be found for the system of cylindrical geometry by solution of the corresponding thermal-conductivity boundary-value problem [7, 8]. The amplitude of the

S. Ordzhonikidze Moscow Aviation Institute. Translated from *Inzhenerno-Fizicheski Zhurnal*, Vol. 34, No. 5, pp. 854-859, May, 1978. Original article submitted May 17, 1977.

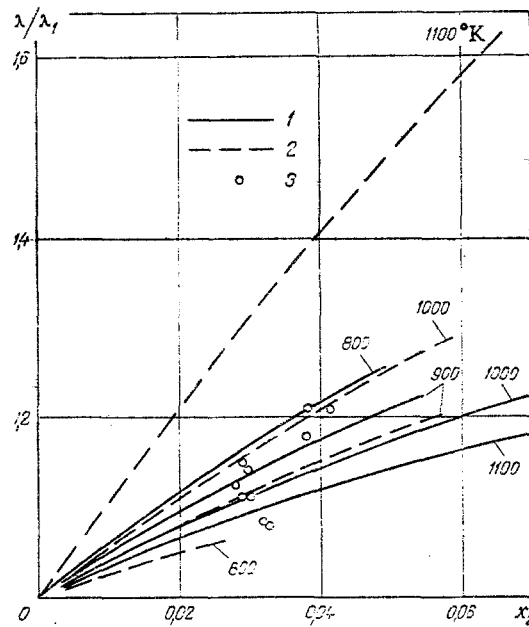

Fig. 1. Thermal conductivity of cesium vapor: 1) data of [2]; 2) [3]; 3) present study.

temperature pulsations is proportional to the third harmonic of the voltage imposed on the filament and can be measured by electrical circuitry. The equation used for calculation of the thermal-conductivity coefficient in this case has the form [8]

$$\frac{U^3 dR/dT}{4\pi LE_3 R^2} = \lambda \sqrt{(xD + \frac{\pi}{4})^2 + (xE + 2c' \rho' r^2 \omega l)^2}, \quad (1)$$

$$x = r \sqrt{2\omega c_p \rho / \lambda}; \quad \omega = \frac{2 - \alpha}{\alpha} \frac{l}{r};$$

$$xD = \frac{\omega - \ln \frac{\gamma x}{2}}{\left(\omega - \ln \frac{\gamma x}{2}\right)^2 + \frac{\pi^2}{16}}; \quad xE = \frac{\frac{\pi}{4}}{\left(\omega - \ln \frac{\gamma x}{2}\right)^2 + \frac{\pi^2}{16}}.$$

On the left side of Eq. (1) there appear quantities directly measurable in an experiment, while the right side is a function dependent on the thermophysical properties of the sensor and the medium and on the frequency ω .

A diagram of the experimental apparatus used to determine the thermal conductivity of cesium vapor is shown in Fig. 2. The measurement cell is a thick-walled molybdenum vessel 1, located in a type SShVL vacuum furnace. The sensor 2 is installed inside the cell on two current leads 3, insulated from each other by a Policor ceramic tube 4. This ceramic does not react with the cesium and provides reliable electrical insulation at the experimental temperatures. The cell temperature is measured by three platinum-platinum/rhodium thermocouples 5. The filling system consists of a vessel with liquid cesium 8, stopcock 7, tubes 6, and two flanges with seals 10. The system allows the cell to be evacuated or filled with inert gas or cesium vapor. Filling with cesium vapor is accomplished with stopcock 7 closed by using argon from tank 9 to drive liquid cesium into ceramic tube 4, where it evaporates in the gap between the ceramic and the current lead. Change in cesium level could be observed through quartz window 9. An equilibrium state is established when the vapor pressure in cell 1 is equal to the argon pressure in the filling tank, which is measured by a reference manometer. Cesium of 99.96% purity was used in the experiments. The impurity content was as follows (%): Na, 0.006; K, 0.011; Rb, 0.018; Ca, 0.003.

The electrical circuitry shown in Fig. 3 measured the electrical parameters appearing in Eq. (1). The circuit consists basically of an equal arm ac bridge, driven by the GZ-18

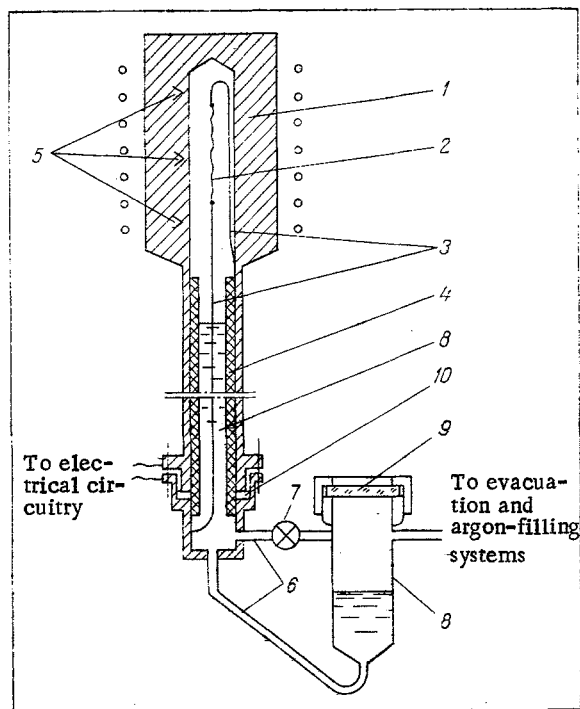

Fig. 2. Diagram of experimental apparatus.

generator, which allowed measurement of the sensor resistance R and separation of the voltage at the tripled frequency E_3 . The F-510 null indicator was used to balance the bridge circuit and also as a selective amplifier when measuring the third harmonic voltage. The remaining equipment, as in [7, 8], was used for calibration of the amplifier circuit and measurement of voltages and frequency. The sensor was a tungsten filament 41.61 mm in length. Before the experiments with cesium, the thermal conductivity of argon was measured at temperatures up to 1200°K, and the results were used to determine the filament radius, which proved to be 3.11 μm . Since the thermal conductivity of cesium is relatively low, the experiments were performed at low frequencies (~ 20 Hz) and pressures of ~ 1 atm, to reduce the effect of the thermal inertia of the filament. The voltage across the filament was chosen so that the temperature pulsation amplitude did not exceed 10°. Before the cesium experiments the dependence of the tungsten filament resistance on the temperature of the argon-filled cell was determined. After filling the cell with cesium a reduction in filament resistance was observed. The measured resistance at a pressure of 1.5 atm comprised $\sim 90\%$ of that at the same temperature in argon, and with increase in temperature and cesium vapor pressure it decreased further. When the cesium vapor was removed from the cell the tungsten filament resistance was reestablished. This resistance decrease can be explained by surface ionization of cesium atoms on the tungsten [9]. Since the filament resistance was known both in the presence of cesium and in an argon atmosphere, it was possible to introduce an appropriate correction for shunting of the filament by an ion current in calculating the thermal conductivity. If the surface ionization is not considered, the λ values obtained will be increased significantly. In contrast to [2], where the correction for radiation comprised 15-40%, and [3], where the correction reached 75% (20-75%), because of the relatively large gap between filament and cylinder in the present experiments, the radiation correction did not exceed 4%. The temperature difference correction did not exceed 1%. The devices used to measure the electrical parameters of Eq. (1) had quite high accuracy (bridge circuit, 0.05%; digital voltmeters, 0.2%; millivoltmeter used for amplifier calibration, 0.5%, etc.) so that the error in determining the complex $(U^3 dR/dT)/4\pi \cdot LE_3 R^2$ did not exceed 2%. However, the necessity of corrections for shunting by ion current and the effect of the thermal inertia of the filament in the case of cesium, which has relatively low thermal conductivity, lead to an increase in the uncertainty of λ determination. We estimate the overall uncertainty of our measurements to be 6%.

Results of the measurements are presented in Fig. 1 and Table 1. As is evident from Fig. 1, our results agree with [2] within the limits of the experimental errors of both studies. The results of [3] at $T = 1100^\circ\text{K}$ lie significantly above ours. It is known that the

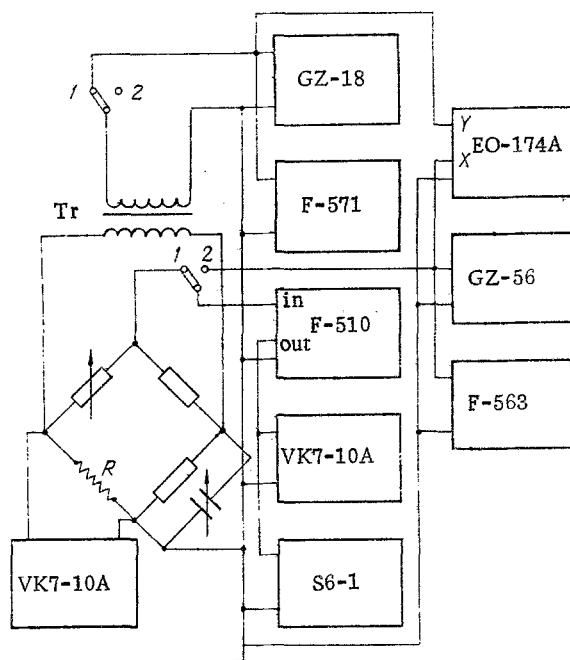

Fig. 3. Electrical circuitry (F-571, frequency meter; S6-1, nonlinear distortion indicator; F-563, millivoltmeter; GZ-56, generator; EO-174A, oscilloscope).

TABLE 1. Experimental Results

T, °K	$P \cdot 10^{-4}$, N/m ²	$\lambda \cdot 10^3$, W/m · °K	$\frac{U^2 dR/dT}{4\pi LE_3 R^2} \cdot 10^3$	T, °K	$P \cdot 10^{-4}$, N/m ²	$\lambda \cdot 10^3$, W/m · °K	$\frac{U^2 dR/dT}{4\pi LE_3 R^2} \cdot 10^3$
1135.9	1,01	8,61	4,319	1153,0	1,033	8,75	4,137
1122,9	1,032	8,29	4,464	1162,5	1,033	8,91	4,189
1121,6	1,013	8,32	4,307	1169,4	1,503	9,37	4,466
1140,3	1,013	8,88	4,323	1168,2	1,503	9,60	4,342
1148,1	1,013	9,00	4,465	1148,9	1,503	9,47	4,670
1150,5	1,013	8,75	4,277				

thermal conductivity of alkali metal vapors can be represented as the sum of the thermal conductivity of the "frozen" mixture λ_f and the thermal conductivity λ_r produced by the dissociation reaction:

$$\lambda = \lambda_f + \lambda_r. \quad (2)$$

To calculate λ_f we use expressions for a binary gas mixture [13] and for λ_r we use the theory of thermal conductivity of a reacting mixture [14], thus obtaining a formula for the ratio λ/λ_1 [15]:

$$\frac{\lambda}{\lambda_1} = 1 + Ax_2 + Bx_2^2 + C \left[\frac{D(T)}{RT} \right]^2 \frac{(1-x_2)x_2}{(1+x_2)^2}, \quad (3)$$

where $D(T)$ is the energy of dissociation, a function weakly dependent on T , and the coefficients A , B , and C are constants for a given substance. It follows from Eq. (3) that the ratio λ/λ_1 for constant x_2 should decrease with increase in temperature. The opposite is found in the results of [3]: λ/λ_1 increases with growth in temperature (Fig. 1), the increase being especially significant at high pressures and temperatures. Such an increase in thermal conductivity can be explained by surface ionization of cesium atoms on tungsten. In accordance with the theory of [9], this effect appears more strongly with increase in pressure and temperature, leading to an elevation of the data obtained at high temperatures and pressures. We note that in experiments on the thermal conductivity of sodium vapor [16] performed with the same apparatus used in [3], λ/λ_1 decreases with increase in temperature. This is completely natural, since the ionization potential of sodium is greater than that of cesium, and in the temperature range considered sodium atom ionization has no significant effect.

NOTATION

$c' \rho'$, volume heat capacity of tungsten; c_p , ρ , λ , heat capacity, density, and thermal conductivity of gas studied; l , mean free path length; r , filament radius; α , thermal accommodation coefficient of atoms on tungsten; $\gamma = 1.7811$; ξ , radiation correction; U , voltage across filament; R , filament resistance; L , filament length; E_3 , amplitude of third-harmonic voltage; x_2 , molar fraction of diatomic molecules in vapor; T , temperature.

LITERATURE CITED

1. C. Lee and C. F. Bonilla, in: *Proceedings of the Seventh Conference on Thermal Conductivity*, National Bureau of Standards, Maryland (1967).
2. N. B. Vargaftik and V. V. Kerzhentsev, *Teplofiz. Vys. Temp.*, 10, No. 1 (1972).
3. D. L. Timrot, V. V. Makhrov, V. I. Sviridenko, and B. F. Reutov, *Teplofiz. Vys. Temp.*, 14, No. 5 (1976).
4. L. I. Zarkova and B. I. Stefanov, *Teplofiz. Vys. Temp.*, 14, No. 2 (1976).
5. G. I. Gushchin, V. A. Subbotin, and É. Kh. Khachaturov, *Teplofiz. Vys. Temp.*, 13, No. 4 (1975).
6. B. I. Stefanov, L. I. Zarkova, and D. Oliver, *Teplofiz. Vys. Temp.*, 14, No. 1 (1976).
7. N. B. Vargaftik, Yu. K. Vinogradov, and N. A. Vanicheva, *Sb. Tr. Mosk. Aviats. Inst.*, No. 319, 59 (1975).
8. N. B. Vargaftik, Yu. K. Vinogradov, and I. A. Khludnevskii, *Thermophysical Properties of Gases* [in Russian], Nauka, Moscow (1973).
9. É. Ya. Zandberg and N. I. Ionov, *Surface Ionization* [in Russian], Nauka, Moscow (1969).
10. N. N. Stolovich and N. S. Minit'skaya, *Temperature Dependences of Thermophysical Properties of Certain Metals* [in Russian], Nauka i Tekhnika, Minsk (1975).
11. A. Kröner, *Ann. Phys.*, 40(4), 438 (1913).
12. M. L. Hackspill, *Ann. Chem. Phys.*, 28(8), 613 (1913).
13. J. O. Hirschfelder, C. F. Curtiss, and R. B. Bird, *Molecular Theory of Gases and Liquids*, Wiley (1964).
14. J. O. Hirschfelder, *J. Chem. Phys.*, 26, 274 (1957).
15. V. S. Yargin, *Sb. Tr. Mosk. Aviats. Inst.*, No. 319, 75-90 (1975).
16. D. L. Timrot, V. V. Makhrov, and V. I. Sviridenko, *Teplofiz. Vys. Temp.*, 14, No. 1 (1976).

DETERMINATION OF THE THERMAL AND ELECTRICAL CONDUCTIVITIES OF ULTRAFINE PARTICULATE SYSTEMS

G. N. Dul'nev, Yu. P. Zarichnyak,
and V. V. Novikov

UDC 536.24:537.321

An ultrafine particulate system with a linear particle deformation close to zero is investigated. The thermal and electrical conductivities are determined with regard for dimensional effects at the contacts.

The figure of merit of thermoelectric materials is governed by the Ioffe parameter $z = \alpha^2 \sigma / \lambda$ [1], which implies that in order to increase the thermoelectric figure of merit at constant α it is necessary to increase the ratio $\beta = \sigma / \lambda$ [1, 2].

There has been recent discussion in the literature of the possibility of increasing the thermoelectric figure of merit of a material on the basis of an ultrafine dispersed system with average linear grain size from 100 to 2000 Å, which has been subjected to superficial sintering. Experimental studies of such a system [3] have shown that the value of z is increased severalfold over the value z_1 for the monolithic material.

An experimental study of σ , α , and λ has been carried out [6] for a high-porosity ($m_2 \approx 0.7$) particulate system with a mean grain size $d \approx 2 \mu\text{m}$ obtained from n-Ge. The ratio $\beta = \sigma / \lambda$

Leningrad Institute of Precision Mechanics and Optics. Translated from *Inzhenerno-Fizicheskii Zhurnal*, Vol. 34, No. 5, pp. 860-869, May, 1978. Original article submitted February 1, 1977.